

NOTES:

1. MOUNTING TYPE: DIN RAIL SIZE 35x7.5 mm.
2. VOLTAGE: 600 V.
3. CURRENT: Cu 150 A, Al 120 A.
3. WIRE CROSS-SECTION RANGE:  
Cu/Al 6-1/0 AWG (13-53 mm<sup>2</sup>) STRANDED,  
Cu 3x8 AWG (3X8.3mm<sup>2</sup>) STRANDED,  
Cu 2X6 AWG (2X13mm<sup>2</sup>) STRANDED.
4. HEAD CAP SCREW WITH 5mm HEXAGON SOCKET SIZE.  
USE A TOOL WITH LENGTH ALLOWING FOR A FULL SCREW ENGAGEMENT.
5. RECOMMENDED TIGHTENING TORQUE:  
90 lb-in (10 Nm).
6. ALL ELECTRICAL AND MECHANICAL SPECIFICATIONS ARE PER UL1059 AS NOTED IN MOLEX UL AGENCY APPROVAL.
7. THE SUITABILITY OF THESE TERMINALS SHALL BE DETERMINED IN THE END-USE INVESTIGATION.
8. AS ENVIRONMENTAL BARRIER DIELECTRIC GREASE MAY BE PRESENT IN THE WIRING CHAMBER. ENSURE TO USE THE RECOMMENDED TIGHTENING TORQUE FOR ALL CONDUCTORS.

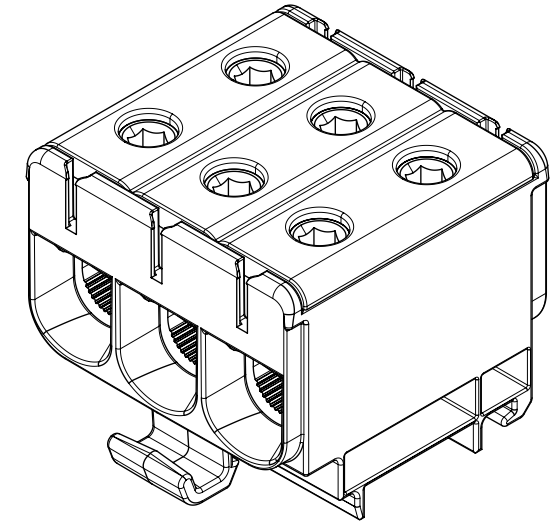
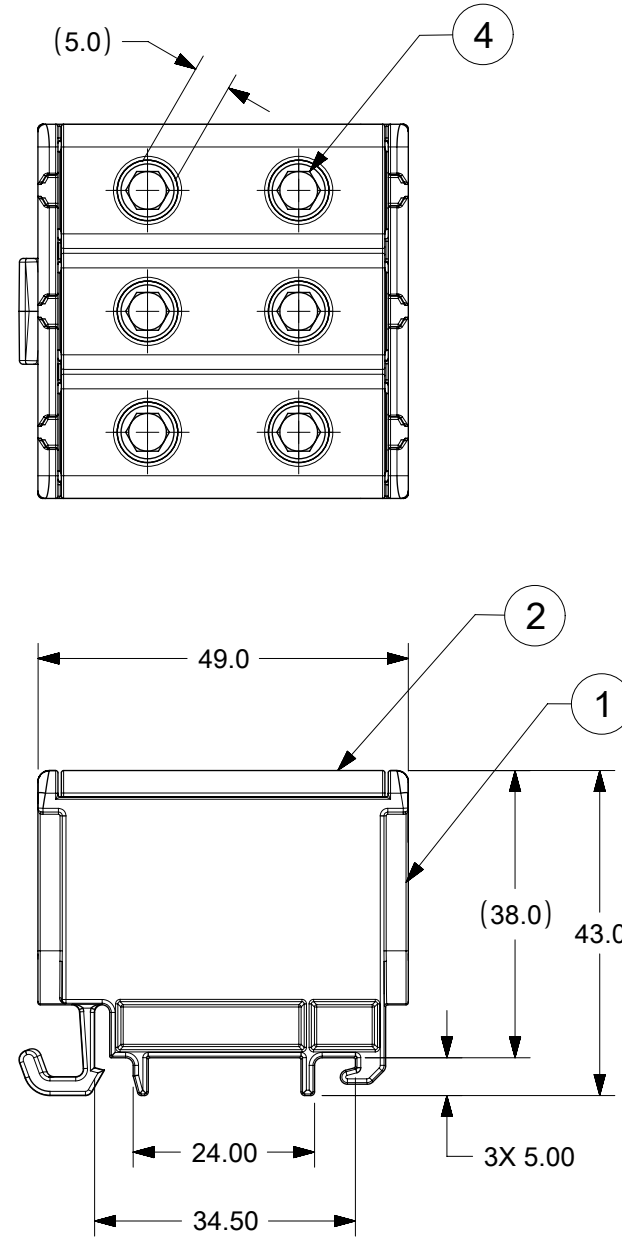

ITEM	QTY	DESCRIPTION	MATERIAL
4	6	SCREW, SET	ALUMINUM
3	3	CAGE	ALUMINUM
2	1	COVER	POLYAMIDE
1	1	HOUSING	POLYAMIDE

TOLERANCE	>0.5=3	>3=6	>6=30	>30=120	>120=400
ISO 2768-m	±0.1	±0.1	±0.2	±0.3	±0.5

THIS DRAWING CONTAINS INFORMATION THAT IS PROPRIETARY TO MOLEX ELECTRONIC TECHNOLOGIES, LLC AND SHOULD NOT BE USED WITHOUT WRITTEN PERMISSION

EC NO: 120665 DRWN: WLEUNG CHKD: DNGUYEN62 APPR: JFMURPHY	2017/08/14 2017/08/15 2017/08/18	GENERAL TOLERANCES (UNLESS SPECIFIED) ANGULAR TOL ± °	DIMENSION UNITS: mm SCALE: 1:1				
	4 PLACES ± 3 PLACES ± 2 PLACES ± 1 PLACE ± 0 PLACES ±	DRWN BY: WLEUNG DATE: 2017/08/14	CHECK'D BY: DNGUYEN62 DATE: 2017/08/15				
	DRAFT WHERE APPLICABLE MUST REMAIN WITHIN DIMENSIONS	APPR BY: JFMURPHY DATE: 2017/08/18	DRAWING SIZE: B THIRD ANGLE PROJECTION	SERIES: 201606 MATERIAL NUMBER: 2016066163	CUSTOMER:		
	A	REV:	B	DOCUMENT NUMBER: 2016066163 DOC TYPE: PSD DOC PART: 000 SHEET NUMBER: 1 OF 1			